

NOTES:

- 1.0.0 ORIENTATIONS
- 1.1.0 WAFER SURFACE IS NORMAL TO Z AXIS WITHIN  $\pm 0.3^\circ$
- 1.2.0 FLATS.
- 1.2.1 MAJOR FLAT IS NORMAL TO THE  $-Y$  AXIS WITHIN  $\pm 0.3^\circ$ .
- 1.2.2 MINOR FLAT IS  $90^\circ \pm 1.0^\circ$  COUNTER-CLOCKWISE FROM THE MAJOR FLAT WHEN VIEWING THE  $-Z$  FACE.
- 2.0.0 SURFACES
- 2.1.0 POLISH
- 2.1.1 THE MINUS Z SIDE POLISHED TO 10-5 SCRATCH DIG
- 2.1.2 THE PLUS Z SIDE POLISHED TO 20-10 SCRATCH DIG
- 2.2.0 EDGE
- 2.2.1 ALL EDGES ROUNDED WITH A  $0.28 \pm 0.08$  mm RADIUS
- 2.2.2 NO CHIPS  $> 0.5$ mm IN PENETRATION AND  $1.0$ mm IN LENGTH.
- 3.0.0 FLATNESS
- 3.1.0 WARP  $< 20$  MICRONS
- 3.2.0 TOTAL THICKNESS VARIATION  $< 6$  MICRONS.
- 4.0.0 MATERIAL
- 5.0 mol% MgO Lithium Niobate
- 4.0.1 Birefringent Phase Matching Temperature for 1064nm laser satisfies  $109^\circ\text{C} < T_{pm} < 116^\circ\text{C}$
- 4.0.2 OH-absorption peak location completely shifted to wavenumber  $3533.6/\text{cm}$
- 5.0.0 Shipment includes Certificate of Compliance 97-03044-01-100 detailing Measurements

REVISIONS					
ZONE	REV	DESCRIPTION	ECO NO.	APPD.	DATE
ALL	A	INITIAL RELEASE	.	JUNDT	01/20/09

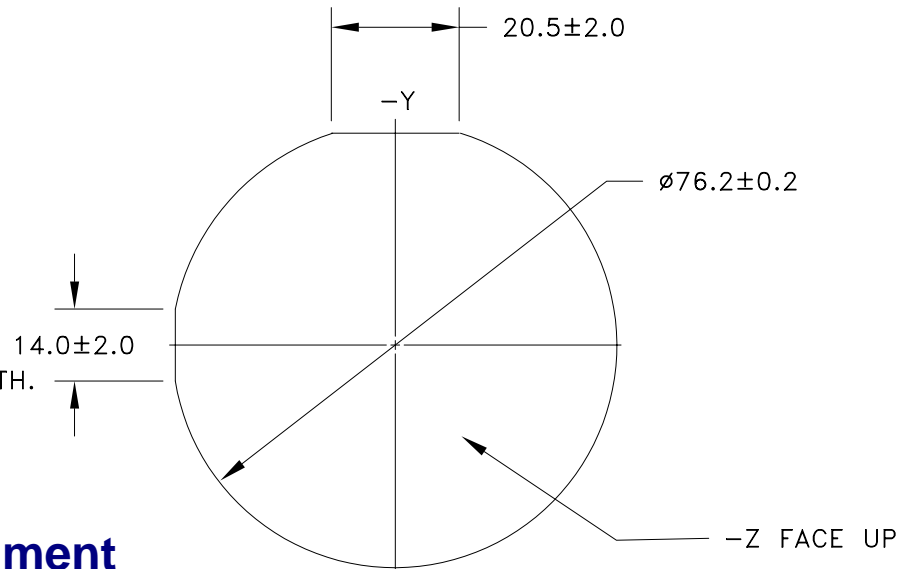

**Document**  
**01/29/09**  
**Control**

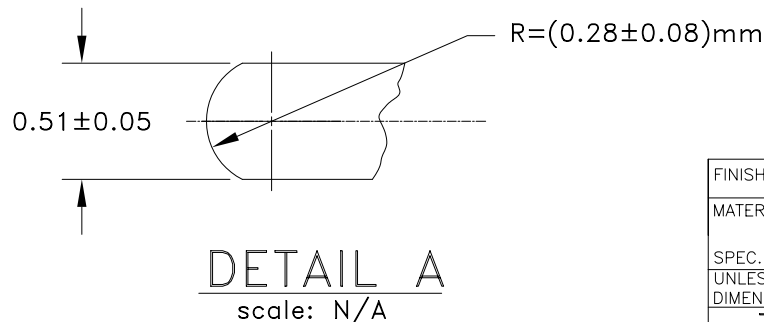
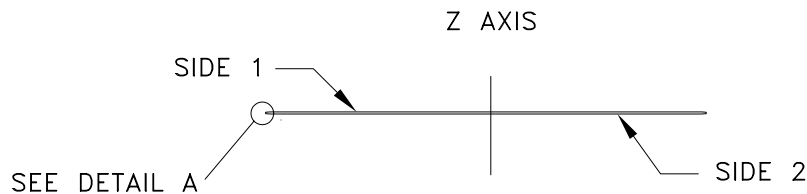

FINISH: SEE NOTES		CONTRACT NUMBER		 <b>Crystal Technology, Inc.</b> AN EPCOS Company
MATERIAL: SEE NOTES		DR. DHJ	1/2009	
SPEC. NO.		CHK.		TITLE: LNMG 5.0%, 3"ø X .02", -Z Po/Po, -Y&-X FLT, TTV<6um
UNLESS OTHERWISE SPECIFIED DIMENSIONS ARE IN mm		APPD.		
TOLERANCES		APPD.		SIZE <b>A</b>
INCHES	MILLIMETERS	WAFER CODE: MNA--Z:076.050DN		DWG. NO. 97-03044-01
.XX ± .01	X.XX ± 0.25	CUSTOMER APPROVAL:		REV. A
.XXX ± .005	X.XXX ± 0.125			
.XXXX ± .0020	SURFACE FINISH 63/	DO NOT SCALE DRAWING		SCALE: N/A
ANG ± .5°				SH. 1 OF 1

THIS DOCUMENT IS THE PROPERTY OF CRYSTAL TECHNOLOGY, INC. IT IS NOT TO BE REPRODUCED OR DISCLOSED IN WHOLE OR IN PART OTHER THAN BY EMPLOYEES OF CRYSTAL TECHNOLOGY AND ITS CONTRACTED REPRESENTATIVES AND DISTRIBUTORS ANY EXCEPTION REQUIRES THE WRITTEN CONSENT OF AN AUTHORIZED REPRESENTATIVES OF CRYSTAL TECHNOLOGY.